

## CHAPTER 11

# PERIMETER AND AREA

---

---

### Points to Remember :

1. Perimeter of a Rectangle =  $2(\text{length} + \text{breadth})$
2. Perimeter of a Square =  $4 \times \text{side}$
3. Area of Rectangle =  $\text{length} \times \text{breadth}$
4. Area of Square =  $(\text{side})^2$
5. Area of Parallelogram =  $\text{base} \times \text{corresponding height}$
6. Area of Triangle =  $\frac{1}{2} \times \text{base} \times \text{corresponding height}$
7. Area of Circle =  $\pi r^2$
8. Circumference of Circle =  $2\pi r$

---

### QUESTIONS

---

1. One of the sides and the corresponding height of a parallelogram are 5 cm and 3 cm respectively. Find the area of the parallelogram.
2. In a triangle, if one side is 7 cm and its corresponding height is 4 cm, find its area.
3. If area of  $\triangle ABC$  is  $49 \text{ cm}^2$  and its height  $AD$  is 7 cm, find  $BC$ .
4. If area of a parallelogram is  $17.6 \text{ m}^2$  and its base is 4 cm, find its corresponding height.
5. Find the breadth of a rectangular plot if its area is  $440 \text{ cm}^2$  and length is 22 cm. Also find its perimeter.
6. The perimeter of a rectangular sheet is 100 cm. If the length is 35 cm, find its breadth.
7. The length and breadth of a rectangular plot are in the ratio of 4 : 3. If the perimeter is 140 cm, find its area.
8. The length and breadth of a rectangular park are in ratio 9 : 5. If its perimeter is 280m, find its area.

9. What is the circumference of a circle whose diameter is 49 m?
10. What is the circumference of a circle whose radius is 14 cm?
11. The radius of a circle is 7 cm. The circle is divided into two equal parts. What is the perimeter of each semi circular part?
12. Find the area of a circle if its radius is 7 cm.
13. The diameter of a circle is 28 cm. Find its area.
14. If the circumference of a circular sheet is 154 cm, find its diameter.
15. Find the circumference of a wheel whose radius is 21 cm. Also find the distance covered by it in 10 revolutions.
16. If the ratio of the diameter of two circles is 2 : 5, find the ratio of their circumferences.
17. The diameter of a car's tyre is 70 cm. Find the distance covered by it in 5 revolutions.
18. The circumference of a circle is 31.4 cm. Find its radius.
19. If the area of a circle is  $154 \text{ cm}^2$ , find its radius.
20. A person starts walking around a square field and in reaching back to the starting place he travels 3496 m. Find the side of the square field.
21. Calculate the breadth of the rectangle whose length and breadth are in the ratio 5 : 7 and perimeter is 120 m.
22. In rectangle  $ABCD$ ,  $AC$  is a diagonal, length = 8 cm and breadth = 5 cm. Find the area of triangle  $ABC$ .

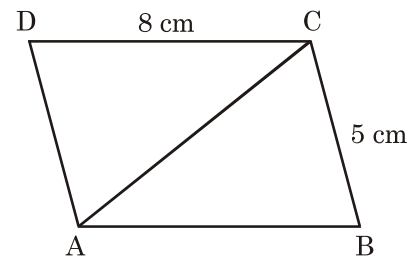

23.  $PQRS$  is a square and it is divided into four triangles as shown below. If a side of the square is 7 cm, find the area of each triangle.

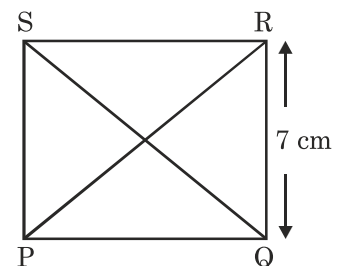

24. Find the area of the parallelograms shown below.

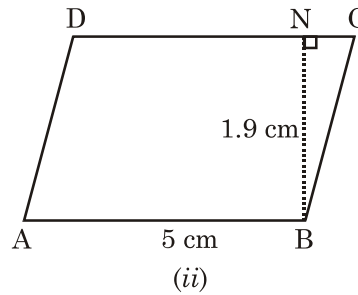
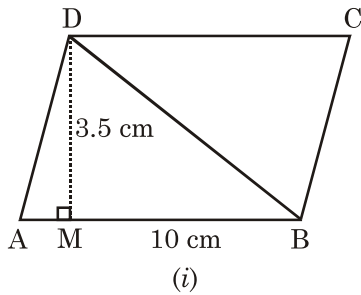

25. Find the height  $x$  if the area of the parallelogram is  $96 \text{ cm}^2$  and its base is 6 cm.

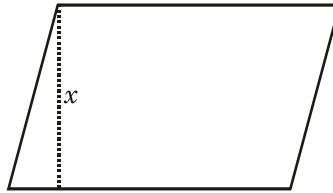

26. Find the area of the given  $\triangle LMN$  if  $LQ = 2 \text{ cm}$ .

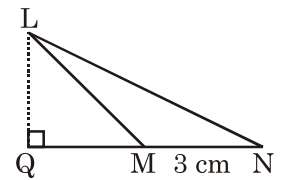

27. Find the area of given  $\triangle ABC$ .

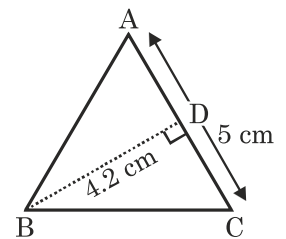

28. Find the perimeter of the given shape.

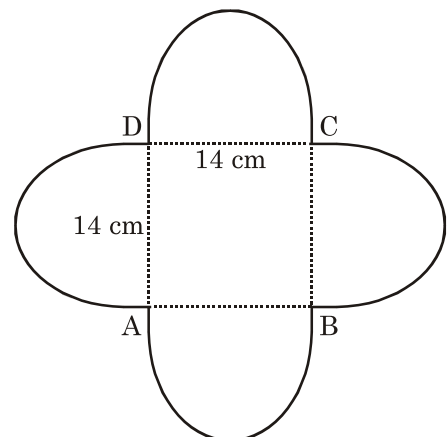

29. A piece of wire is 40 cm long. It is bent in the form of a square. Find its side.
30. A horse is tied with a rope in the centre of a square field of side 30 m. If the length of the rope is 14 m. Find the area of the field where horse cannot graze?
31. The given figure represents a rectangular field with a square flower bed in the middle. Find the area of the lawn excluding the area of the flowerbed.

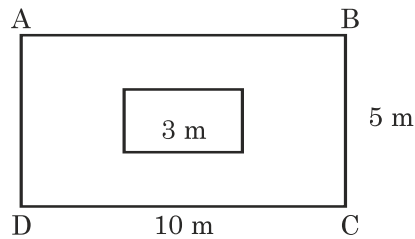

32. From a circular card of radius 7 cm, a rectangular sheet of dimension 2 cm  $\times$  1 cm is removed. (See the given figure). Find the area of the remaining card.

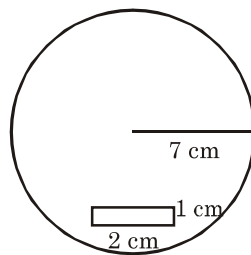

33. Find area of the shaded portion.

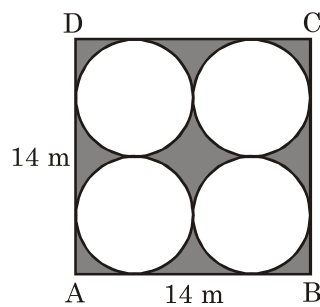

34. Find the perimeter of the given figure, which is a semicircle including its diameter.

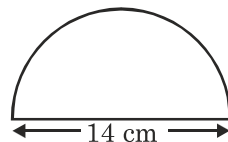

35. From a rectangular piece, a triangular portion is removed as shown in the Fig. Find the remaining area.

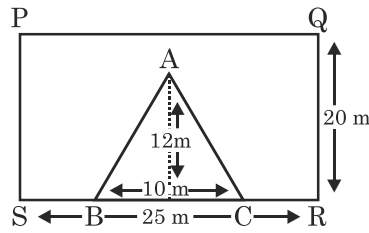

36. Find the width of the rectangle in the following figure if length of the wire is same for triangle and rectangle both.

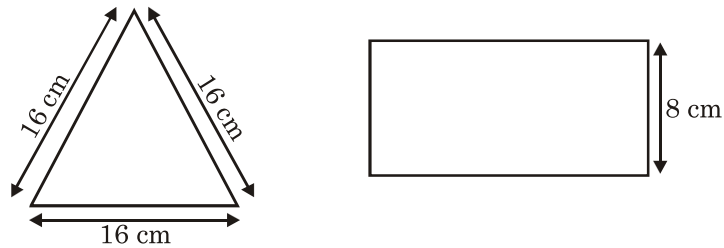

37. A park is in the shape of rectangle as shown. Square flower beds are made at each corner. Find the area of the flowerbeds.

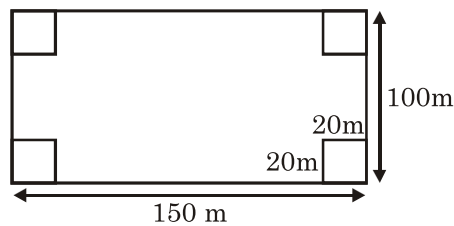

38. Chess Board is to be made as shown below. Find the side of each small square.

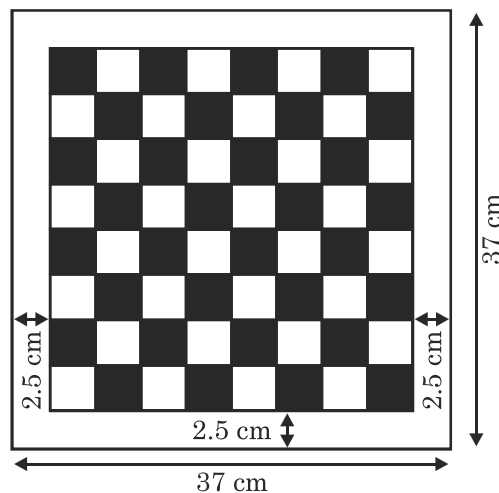

39. For a Home Science practical, 200 students were given cloth pieces of size  $20\text{ cm} \times 25\text{ cm}$ . Find the total cost of cloth @ Rs. 50 per  $\text{m}^2$ .

40. Two squares are made of wire as shown. Find the side of the square whose area is equal to the sum of the areas of these two squares.

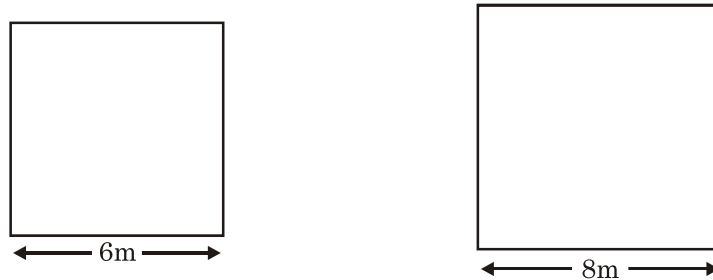

41. Calculate the side of the square whose area is equal to the sum of the areas of these two rectangles.

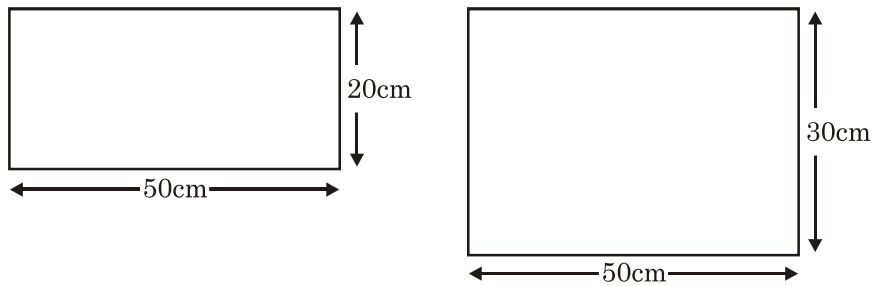

42. Out of a rectangular sheet of paper, a strip is cut (as shown in the figure given below). Find the area of the remaining portion.

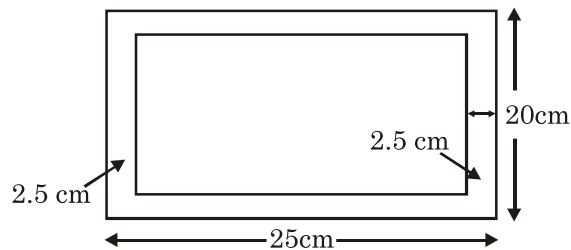

43. For making a paper bag, a rectangle  $15\text{ cm} \times 10\text{ cm}$  is required. Find the cost of 10 paper bags if cost of paper is Rs. 2 per  $\text{cm}^2$  and labour cost is Rs. 5 per bag.
44. Out of a square of side 10 cm, a strip is cut from all sides (as shown in the figure given below). Find the area of strip cut.

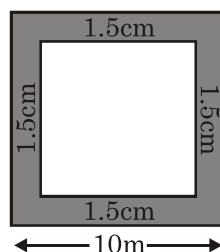

45. Find the width of the rectangle in following if length of wire remains same in both cases.

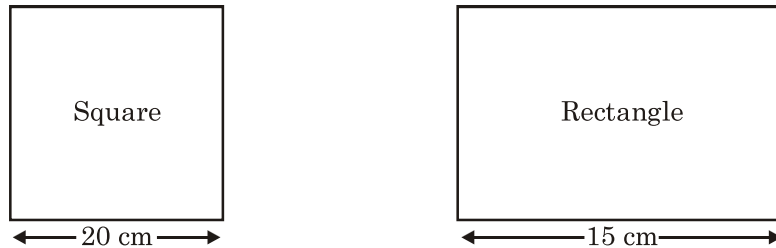

46. A boundary is to be made for a picture as shown in the figure below. Find the area of the whole picture including boundary.

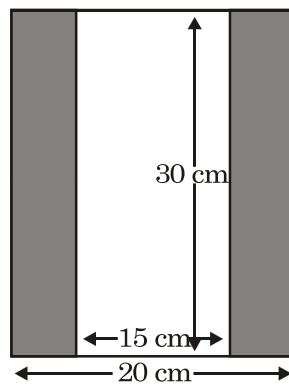

47. Inside a square park of side 100 m, a rectangular musical fountain is to be made and remaining portion is grassy. Find the area of grassy portion.

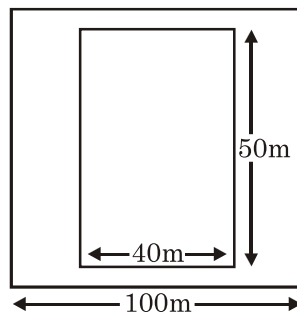

48. Inside a rectangular park, a path of width 5 m is to be made along all sides. Find the area of the path.

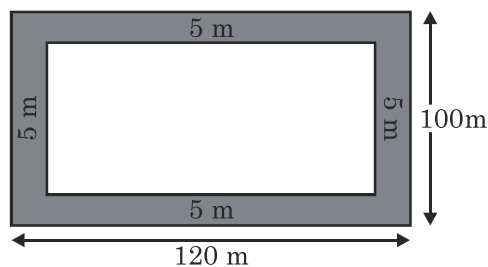

49. A wooden frame is to be made outside a picture as shown in the figure given below. Find the area of wood required.

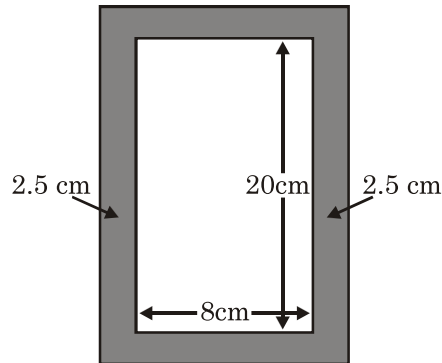

50. A rectangular ground needs fencing on 3 sides as a wall of length 100 m will act as fence on the fourth side. Find the cost of fencing @ Rs. 15 per meter.

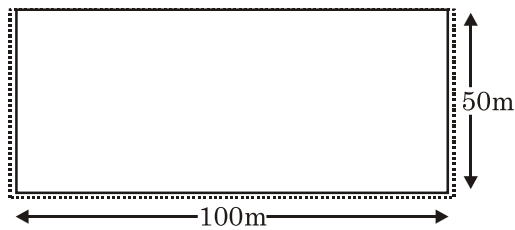

---

### ANSWERS

---

- |  |   |
|--|---|
| 1. $15 \text{ cm}^2$                         | 2. $14 \text{ cm}^2$                              |
| 3. 14 cm                                     | 4. 4.4 cm   |
| 5. $b = 20 \text{ cm}$ ; $P = 84 \text{ cm}$ | 6. Breadth = 15 cm                                |
| 7. $1200 \text{ cm}^2$                       | 8. $4500 \text{ m}^2$                             |
| 9. 154 m                                     | 10. 88 m  |
| 11. 36 cm                                    | 12. $154 \text{ cm}^2$                            |
| 13. $616 \text{ cm}^2$                       | 14. 49 cm   |
| 15. 132 cm, 1320 cm or 13.2 meter            | 16. 2 : 5   |
| 17. 11 m                                     | 18. 5 cm  |
| 19. $r = 7 \text{ cm}$                       | 20. 874 m   |
| 21. 35 cm                                    | 22. $20 \text{ cm}^2$                             |
| 23. $12.25 \text{ cm}^2$                     | 24. (i) $35 \text{ cm}^2$ (ii) $9.5 \text{ cm}^2$ |
| 25. 16 cm                                    | 26. $3 \text{ cm}^2$                              |

- |                         |                        |
|-------------------------|------------------------|
| 27. $10.5 \text{ cm}^2$ | 28. 88 cm              |
| 29. 10 cm               | 30. $284 \text{ cm}^2$ |
| 31. $41 \text{ m}^2$    | 32. $152 \text{ cm}^2$ |
| 33. $42 \text{ m}^2$    | 34. 36 cm              |
| 35. $440 \text{ m}^2$   | 36. 16 cm              |
| 37. $1600 \text{ m}^2$  | 38. 4 cm               |
| 39. Rs. 500             | 40. 10 m               |
| 41. 50 cm               | 42. $300 \text{ cm}^2$ |
| 43. Rs. 3050            | 44. $51 \text{ cm}^2$  |
| 45. 25 cm               | 46. $600 \text{ cm}^2$ |
| 47. $8000 \text{ m}^2$  | 48. $2100 \text{ m}^2$ |
| 49. $165 \text{ cm}^2$  | 50. Rs. 3000.          |

---

### RAPID FIRE

---

1. What is the area of a square whose perimeter is 40 cm?
2. Find the area of a rectangle whose dimensions are  $5 \text{ cm} \times 4 \text{ cm}$ .
3. Find the perimeter of a rectangle whose length is 7.6 cm and breadth is 2.4 cm.
4. Find the area of a square whose side is 6.5 cm.
5. Find the area of a triangle which has base = 10 cm and altitude = 2 cm.
6. Find the perimeter of a square field whose side is 3.5 cm.
7. What is the area of a circle whose radius = 7 cm?
8. If the radius of a circle is 14 cm, find its circumference.
9. Find the area of a parallelogram having base = 15 cm and corresponding altitude = 9 cm.
10. If the area of a square is  $196 \text{ cm}^2$ , find its side.

---

## ANSWERS

---

1.  $100 \text{ cm}^2$

2.  $20 \text{ cm}^2$

3.  $20 \text{ cm}$

4.  $42.25 \text{ cm}^2$

5.  $10 \text{ cm}^2$

6.  $14 \text{ cm}$

7.  $154 \text{ cm}^2$

8.  $88 \text{ cm}$

9.  $135 \text{ cm}^2$

10.  $14 \text{ cm}$